

# MOST ČEZ KRKO NA OBVOZNICI NOVEGA MESTA 01

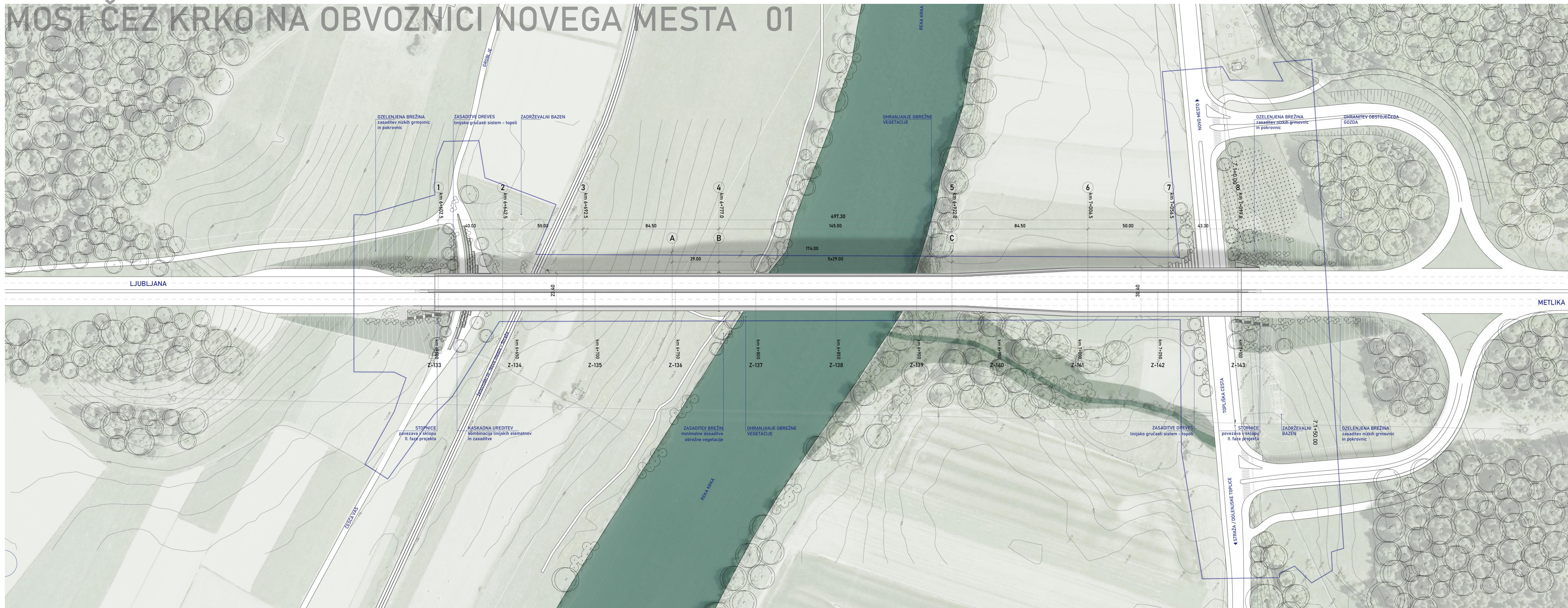

OBVEZNI POGLED 1



OBVEZNI POGLED 2

# MOST ČEZ KRKO NA OBVOZNICI NOVEGA MESTA 02

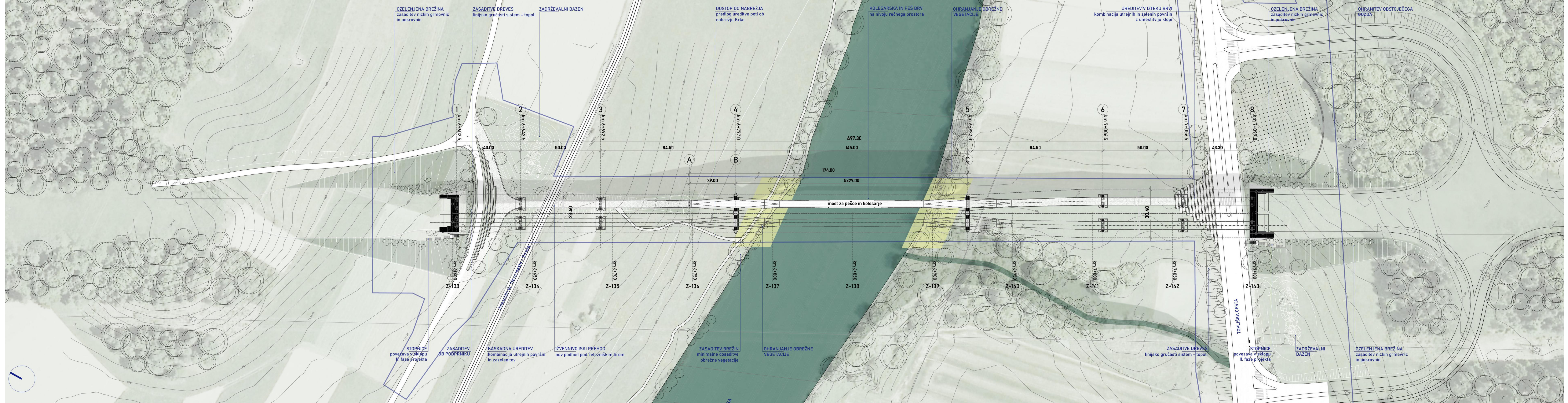

UREĐITVENA SITUACIJA - NIVO KOLESARSKA IN PEŠ BRVI 1:1000

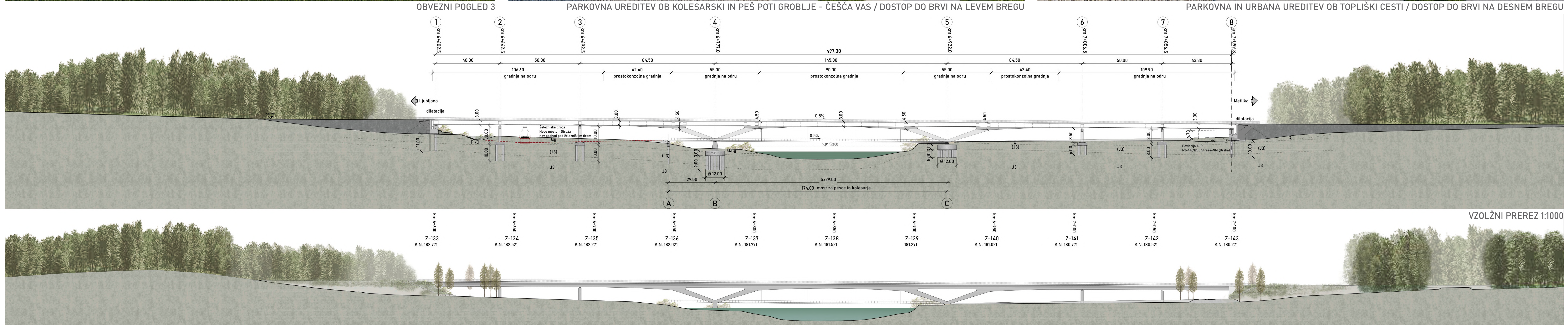

VZOLŽNI PREREZ 1:1000

SKUPNI POGLED 1:1000

# MOST ČEZ KRKO NA OBVOZNICI NOVEGA MESTA 03

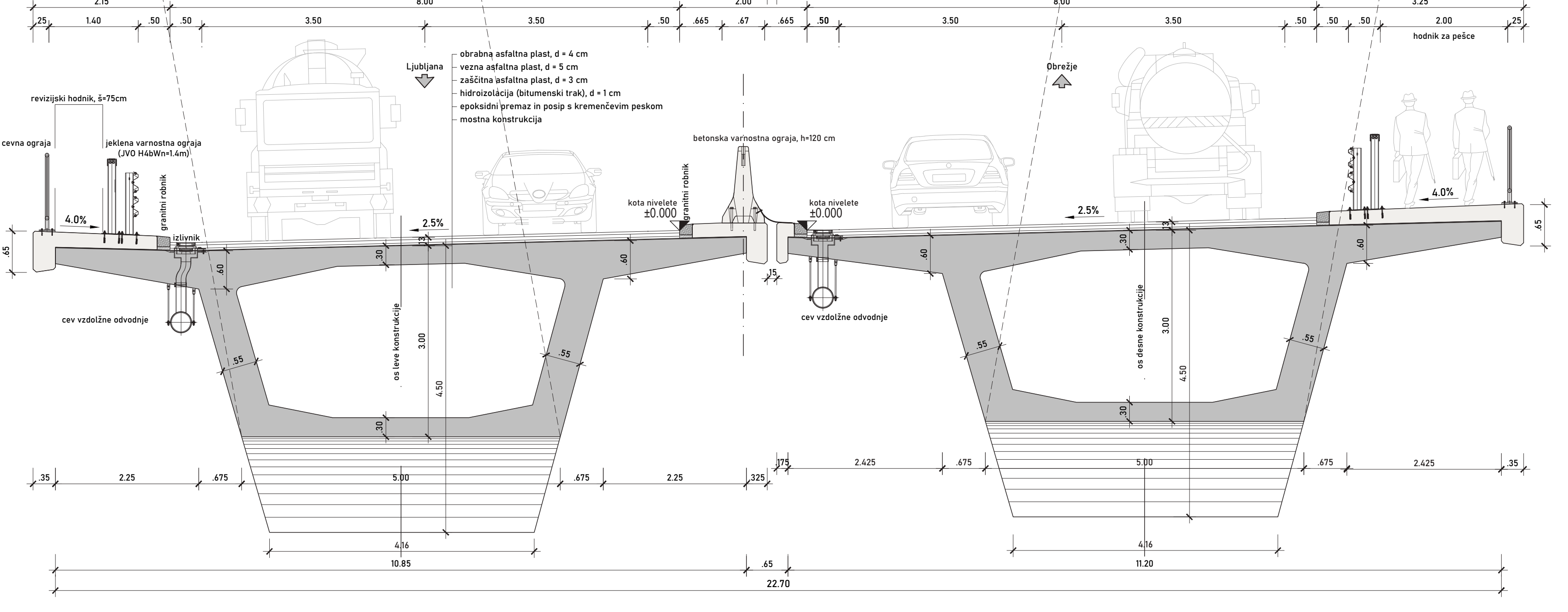
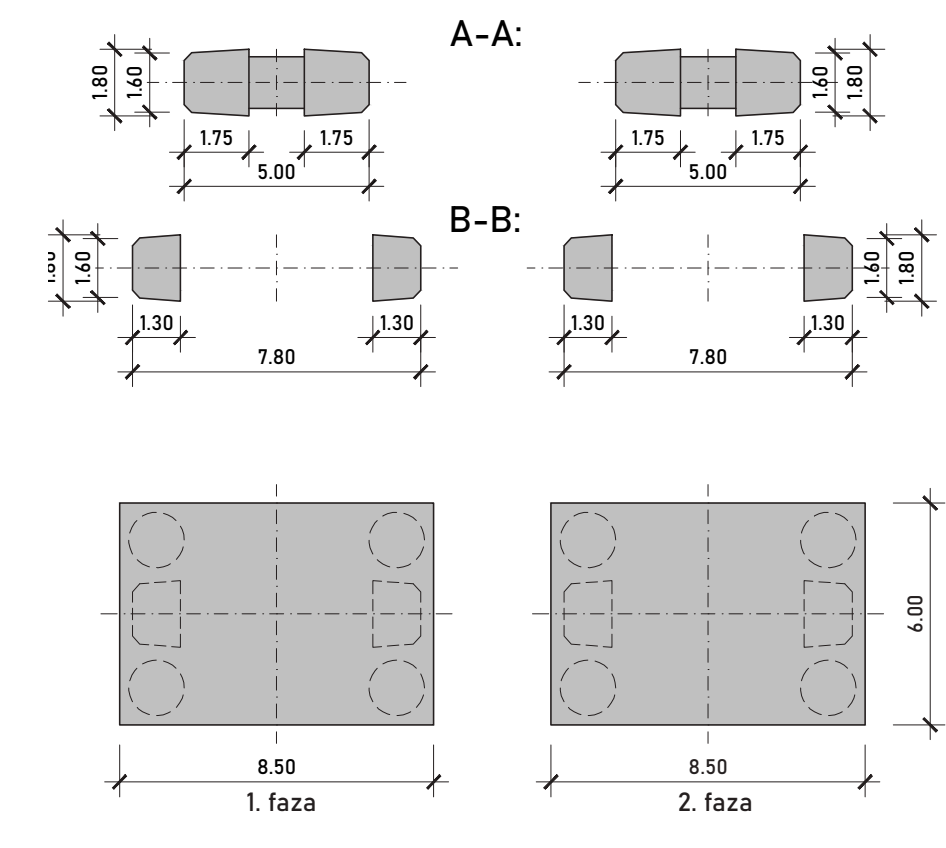
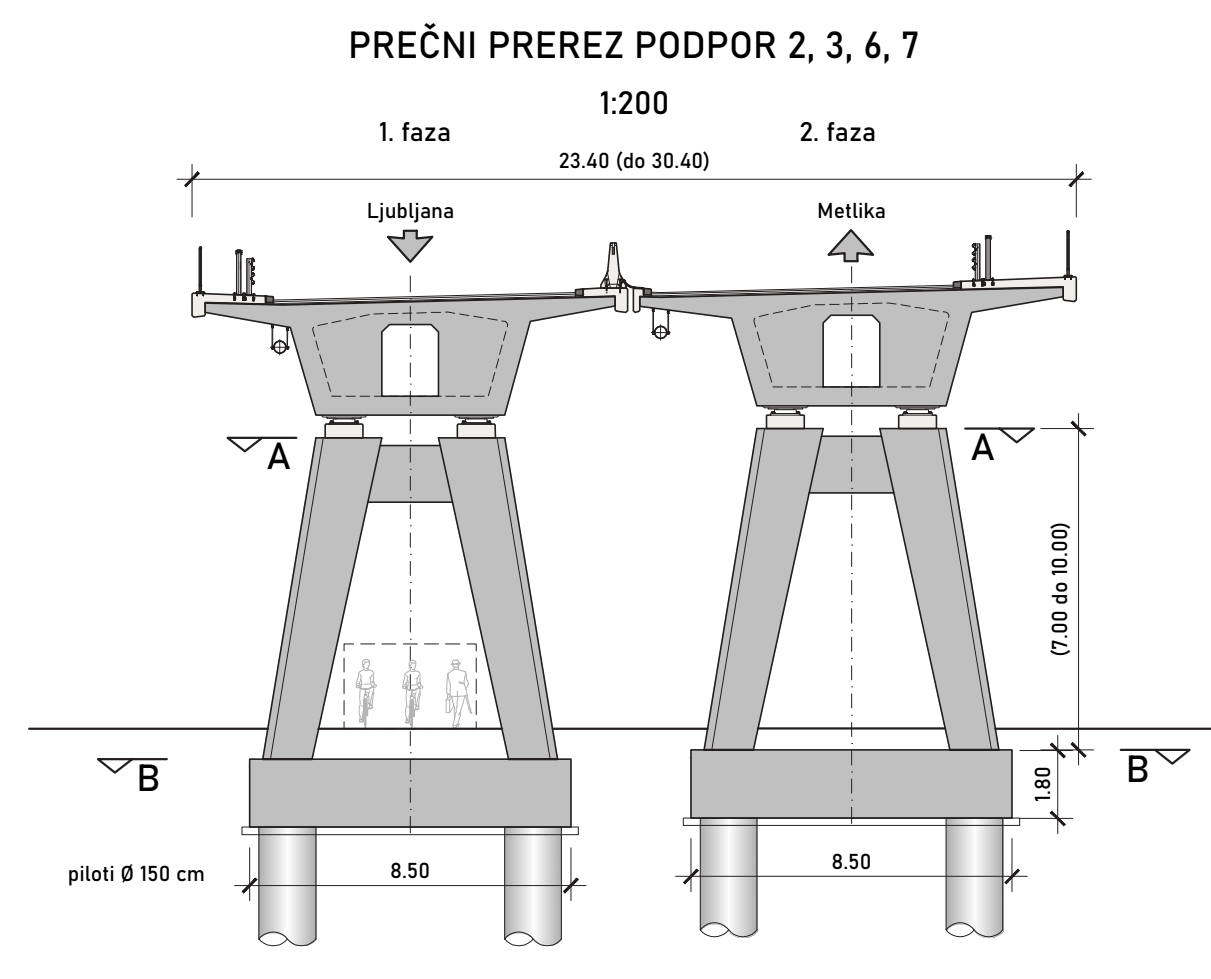
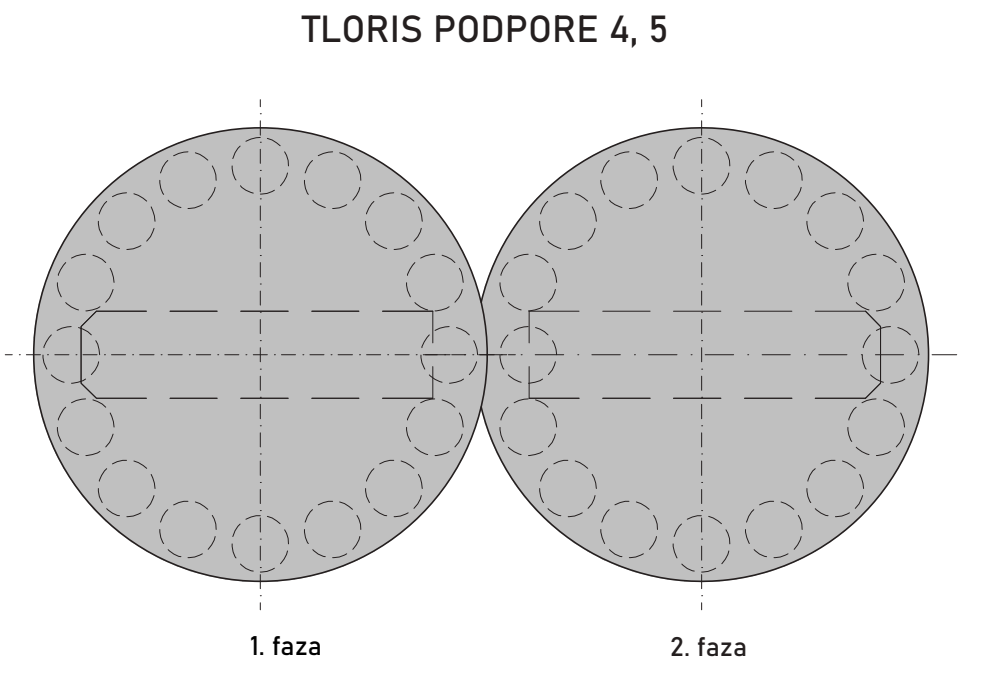
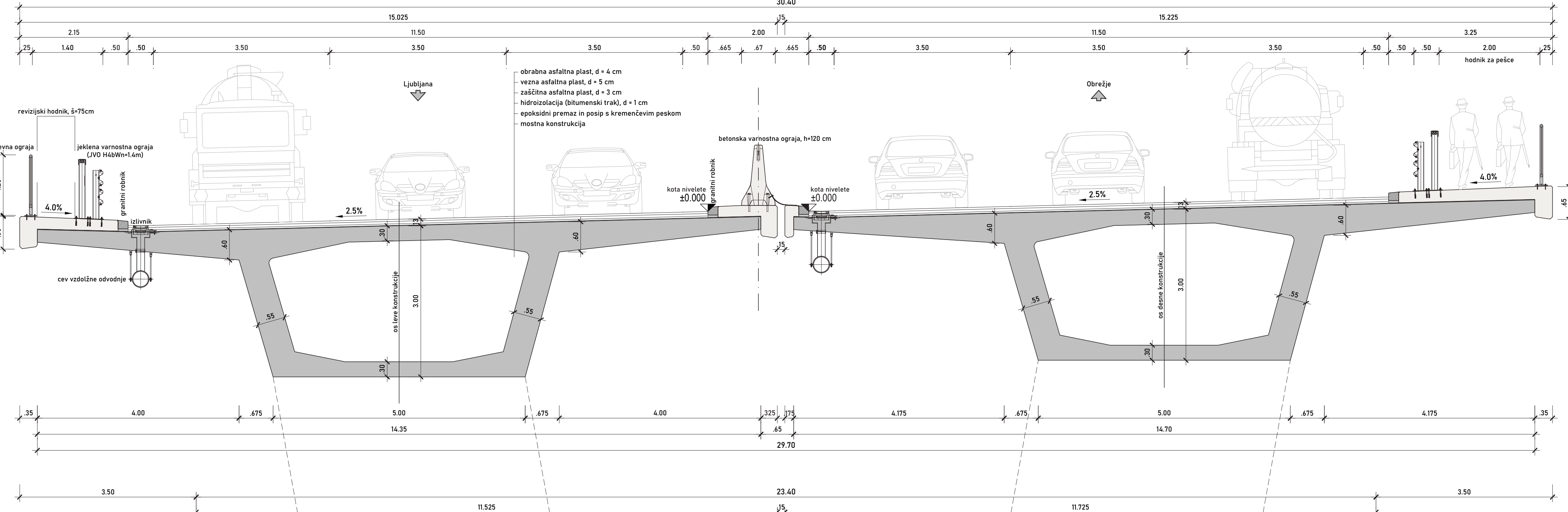
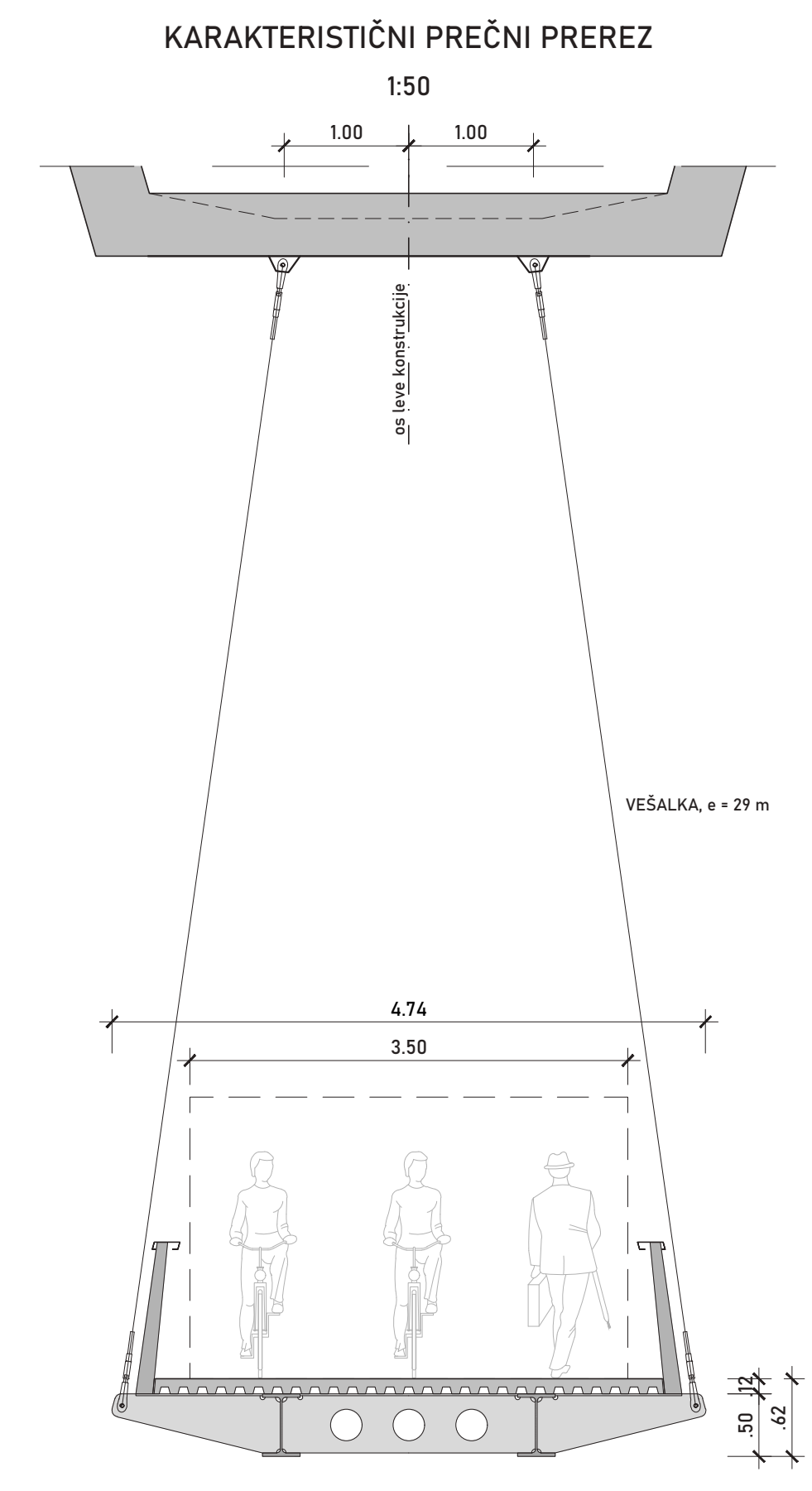
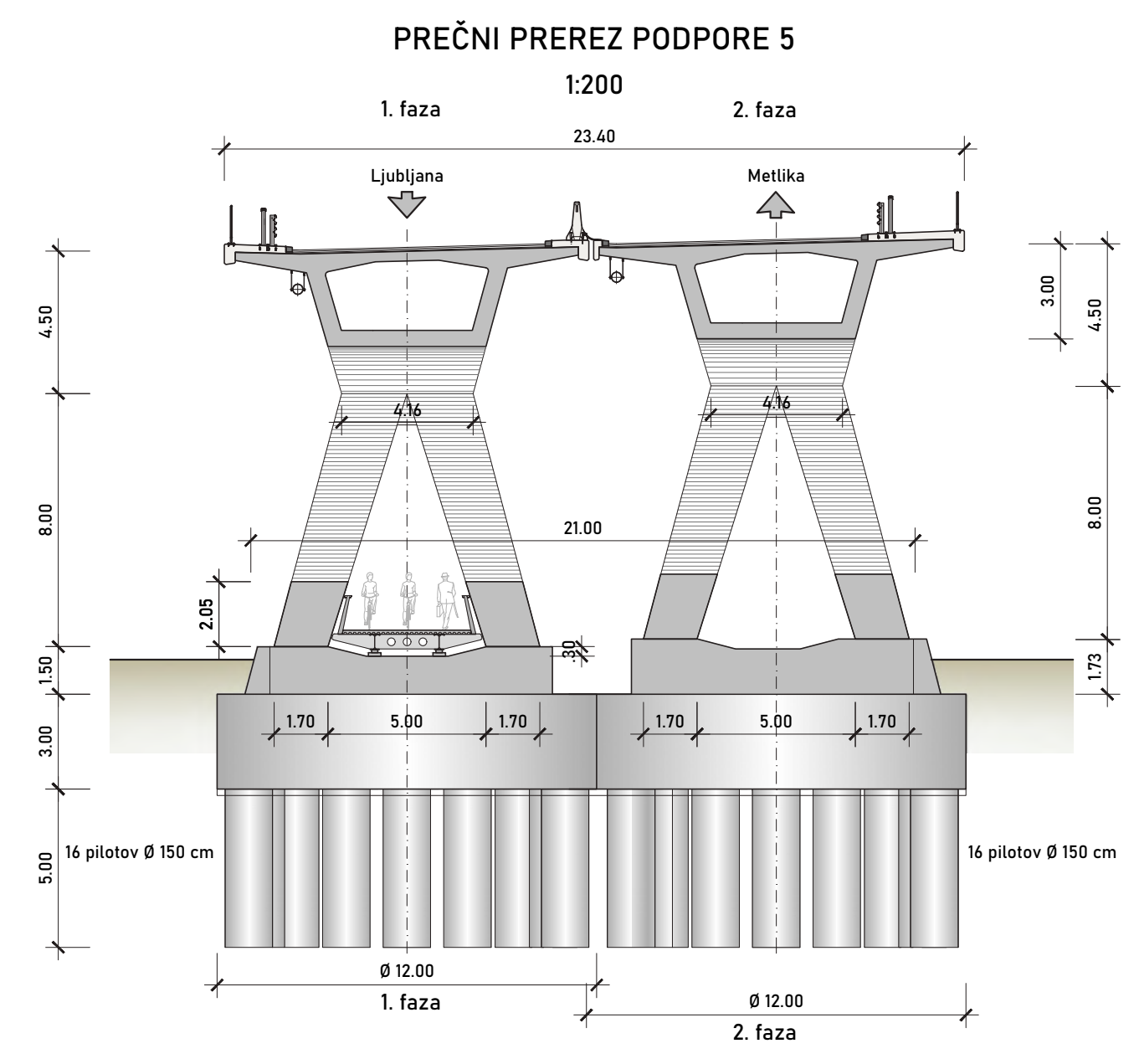

PREČNI PREREZI PODPOR IN OBEŠENE BRVI

KARAKTERISTIČNI PREREZ 1:50



POGLLED NA MOST IN DOLINO KRKE - GORVODNO

# MOST ČEZ KRKO NA OBVOZNICI NOVEGA MESTA 04



POGLED NA MOST Z OBEŠENO KOLESRASKO IN PEŠ BRVJO



POGLED NA MOST IN BRV Z NIVOJA REKE



POGLED S KOLESARSKE IN PEŠ BRVI